

TS Series 30



Your recycling needs. Our grinding solutions.

Series of granulators designed for inline recovery of full sheet at start-up, thermoformed and perforated sheet of PP, PS, PET, PLA and Coex ones.

Grinding of sheet with cups up to 120 mm height; grinding of thermoformed and warm sheet, thanks to the water cooling system of the grinding chamber.

Traction units with adjustable speed and anti-slip knurled rollers, ensure the granulators to work in perfect synchrony with the thermoformer.

The new integral soundproof box placed on the ground allows a considerable reduction of the sound level.

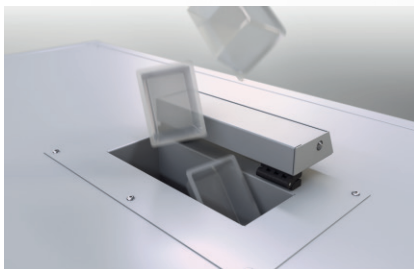

Additional and optional hopper for off-line parts recovery.

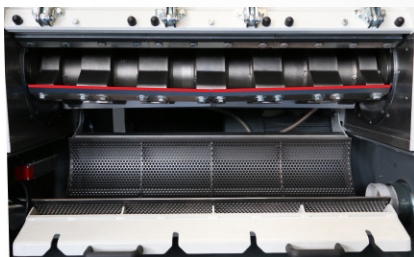

Arrow cutting configuration. Bench adjustment of rotating and fixed knives. Screen equal to approximately 50% of the knives rotation length.



Access without tools to the main parts subject to ordinary maintenance. Maintenance from one side only without tilting.



New redesigned pneumatic dancing arm that guarantees the process of every type of sheet from full sheet to full sheet with cups still attached.

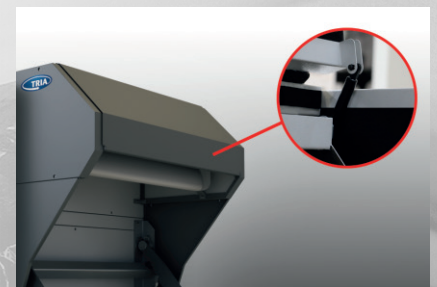

Main soundproof frontal feeding area with a gas assist piston to facilitate the opening and closing.

TS Series 30

FEATURES TS 9030

Feeding opening (mm): 950 x 120
 Manual feeding opening (mm): 240 x 120
 Max sheet width (mm): 930
 Nr. rotating / fixed knives: 3 / 2
 Rotor speed (RPM): 500
 Rotor diameter (mm): 300
 Infeed rollers diameter (mm): 130
 Infeed speed* (m/min): 12 ÷ 30
 Motors [TS + Motorized roller] (kW): 15 + 1,1
 Free roller (kW): 1,1
 Weight (kg): 1900
 Standard screen (mm): 8
 Type of cutting: **arrow**
 Start-up throughput (kg/hr) PP & PET**: 800
 Indicative throughput (kg/hr) PP & PET**: 600
*[*adjustable through inverter]*
*[**depends on thickness and material (PS ~ +20%)]*

FEATURES TS 15030

Feeding opening (mm): 1590 x 120
 Manual feeding opening (mm): 240 x 120
 Max sheet width (mm): 1570
 Nr. rotating / fixed knives: 3 / 2
 Rotor speed (RPM): 500
 Rotor diameter (mm): 300
 Infeed rollers diameter (mm): 130
 Infeed speed* (m/min): 12 ÷ 30
 Motors [TS + Motorized roller] (kW): 18,5 + 1,1
 Free roller (kW): 1,1
 Weight (kg): 2500
 Standard screen (mm): 8
 Type of cutting: **arrow**
 Start-up throughput (kg/hr) PP & PET**: 1200
 Indicative throughput (kg/hr) PP & PET**: 900
*[*adjustable through inverter]*
*[**depends on thickness and material (PS ~ +20%)]*

FEATURES TS 12030

Feeding opening (mm): 1270 x 120
 Manual feeding opening (mm): 240 x 120
 Max sheet width (mm): 1250
 Nr. rotating / fixed knives: 3 / 2
 Rotor speed (RPM): 500
 Rotor diameter (mm): 300
 Infeed rollers diameter (mm): 130
 Infeed speed* (m/min): 12 ÷ 30
 Motors [TS + Motorized roller] (kW): 15 + 1,1
 Free roller (kW): 1,1
 Weight (kg): 2200
 Standard screen (mm): 8
 Type of cutting: **arrow**
 Start-up throughput (kg/hr) PP & PET**: 1000
 Indicative throughput (kg/hr) PP & PET**: 750
*[*adjustable through inverter]*
*[**depends on thickness and material (PS ~ +20%)]*

OPTIONAL

- A) Manual feeding opening
- B) Second motorized roller
- C) Level control

DIMENSIONS	A	B
TS 9030	1700	1158
TS 12030	2018	1476
TS 15030	2336	1794

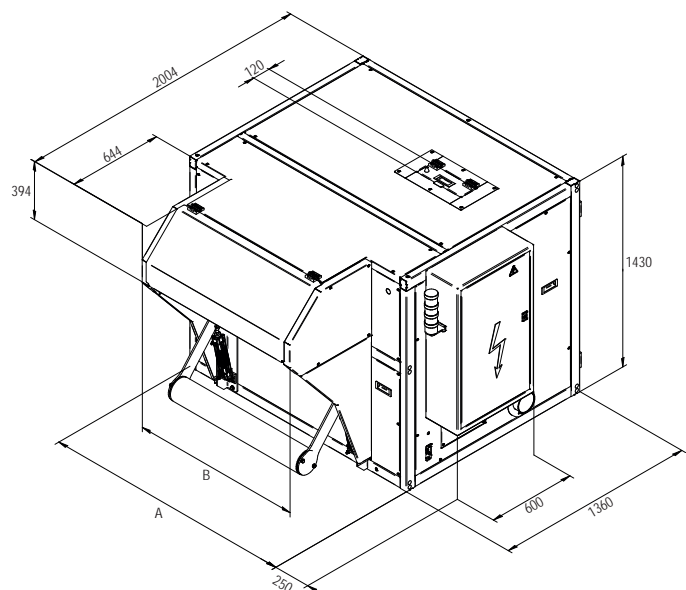

Your recycling needs. Our grinding solutions.

TRIA Italy
www.trioplastics.com

TRIA America
 TRIA Brazil

TRIA China
 TRIA Germany