

TRK Series 30

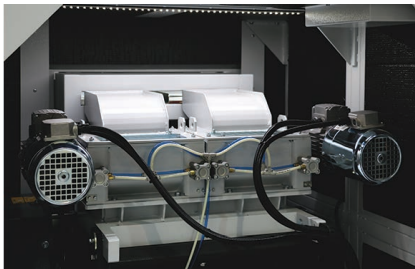

Your recycling needs. Our grinding solutions.

Extremely silent machines, designed to satisfy: customers' growing needs from edge trims to sheet extrusion recovery in PS, PP, PET, PA with thickness 0,1÷3,0 mm, special needs due to the use of hardest resins and to speed increases and thickness requiring better granulators performances.



Independent traction groups for two rollers.

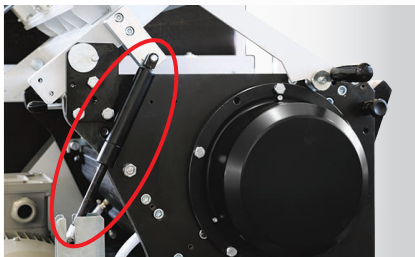

Gas cylinder for traction groups lifting and safety bar.

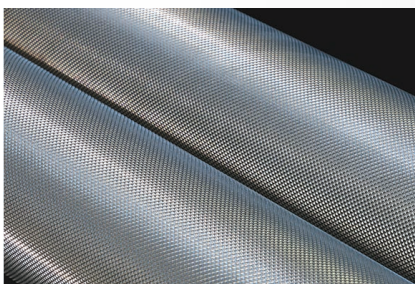

Rollers pneumatic closure with thickness automatic adjustment; different rollers surfaces in relation with the material.



Edge trims feeding speed adjustment by inverter, synchronized with the extrusion line.



Easy access from one side only to all the parts interested for ordinary maintenance.

TRK Series 30

FEATURES TRK 5030

Feeding opening (mm): 500 x 200
Nr. rotating / fixed knives: 3 / 2
Single traction group (mm): 400
Double traction group (mm): 200
Rotor speed (RPM): 350
Rotor diameter (mm): 260
Infeed speed (m/min): 5 ÷ 100
Motors (kW): 7,5 + 0,37
Double rollers (kW): 0,37
Weight (kg): 1000
Standard screen (mm): 7
Type of cutting: scissor
Indicative throughput (kg/hr)*: 150 ÷ 200
*(*depends on speed, thickness and material)*

DIMENSIONS

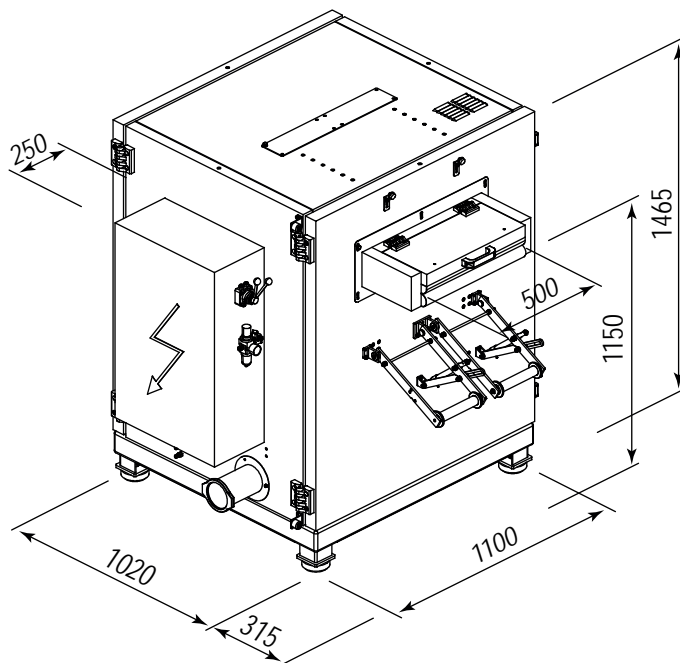

OPTIONAL

- A) Dancing arms with potentiometers
- B) Smooth roller surface (thk < 1,5 mm)
- C) Knurled roller surface (thk > 1,5 mm)
- D) Level control
- E) Knives in antiwear execution
- F) Screen in antiwear execution

ACCESSORIES

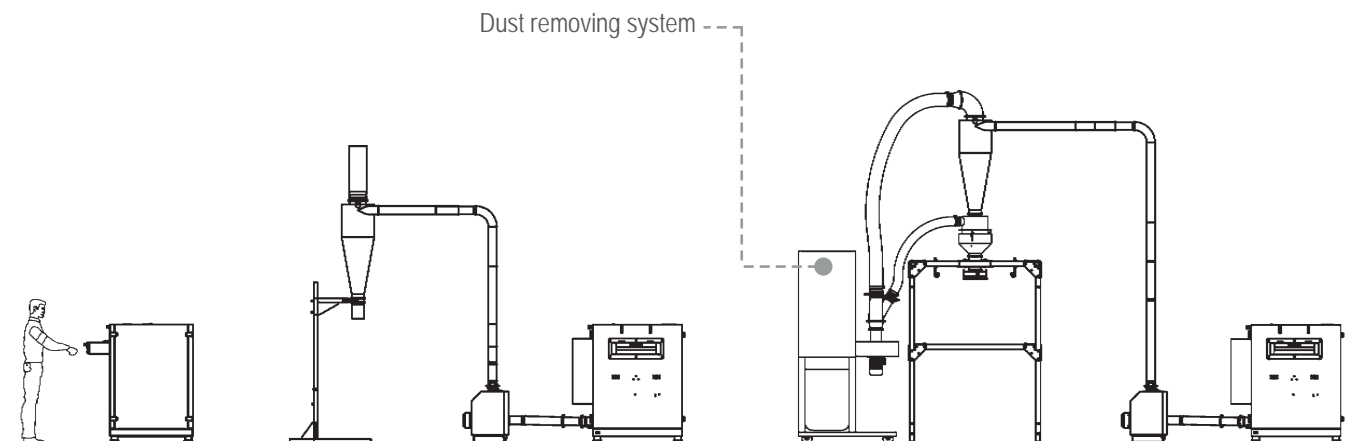

Your recycling needs. Our grinding solutions.

TRIA Italy
www.trioplastics.com

TRIA America
TRIA Brazil

TRIA China
TRIA Germany