

TPL Series 42



Your recycling needs. Our grinding solutions.

The extrusion of profiles involves the production of bulky scraps, that must be quickly grinded with simple feeding by small granulators.

These requirements are satisfied by TPL new version machines for offline grinding of profiles with height up to 200 mm, pipes, tubes and sheets.



Access without tools to the main parts for ordinary maintenance; soundproofing on board, to be used also in operator area.



Grinding of profiles, pipes and sheets; easy manual feeding from the ground (max 1,5 m).



Controls and security system easily reachable by the operator. Safety devices and circuit in compliance with EEC Directives.



TPL Series 42

FEATURES TPL 6042

Feeding opening (mm): 520 x 120
 Nr. rotating / fixed knives: 3 / 2
 Rotor speed (RPM): 330
 Rotor diameter (mm): 360
 Motor (kW): 22
 Weight (kg): 1900
 Standard screen (mm): 7 - 9
 Indicative throughput (kg/hr)*: 300 ÷ 500
 Type of cutting: arrow
 Handling: forklift
 Control panel: on board

(*depends on speed, thickness and material)

FEATURES TPL 9042

Feeding opening (mm): 800 x 120
 Nr. rotating / fixed knives: 3 / 2
 Rotor speed (RPM): 330
 Rotor diameter (mm): 360
 Motor (kW): 22
 Weight (kg): 2300
 Standard (mm): 7 - 9
 Indicative throughput (kg/hr)*: 400 ÷ 600
 Type of cutting: arrow
 Handling: forklift
 Control panel: on board

(*depends on speed, thickness and material)

DIMENSIONS

	A	B	C	D
TPL 6042	1210	1700	1170	1300
TPL 9042	1490	1700	1170	1300

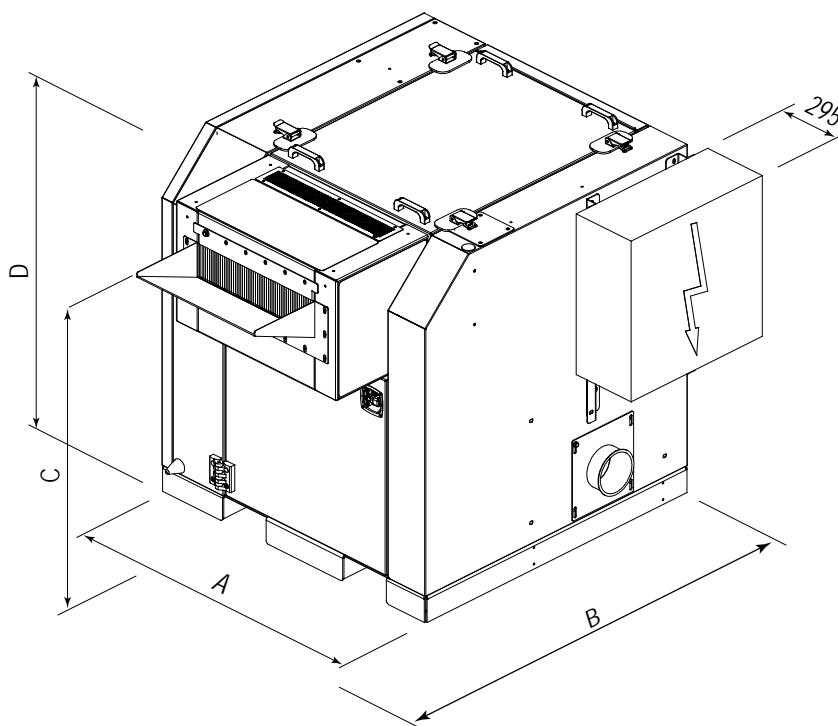

ACCESSORIES

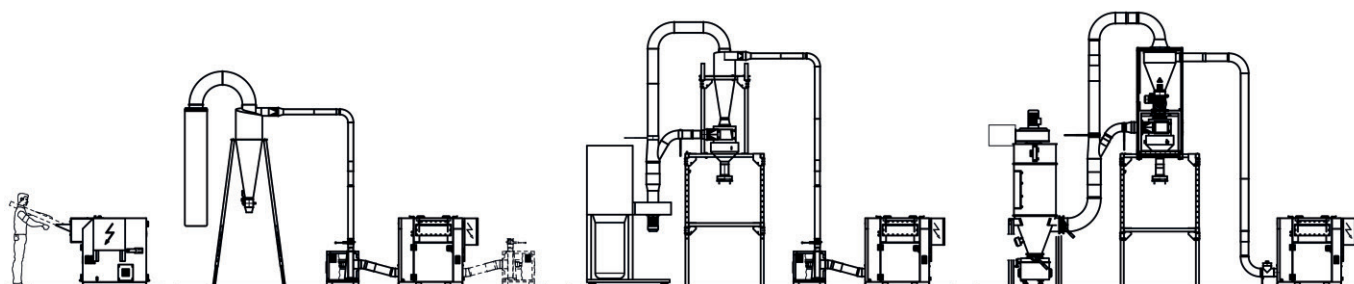

Your recycling needs. Our grinding solutions.

TRIA Italy
www.trioplastics.com

TRIA America
 TRIA Brazil

TRIA China
 TRIA Germany