

# JS Series 11

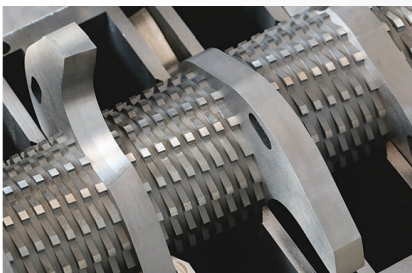

Your recycling needs. Our grinding solutions.

Technical moulds, reinforced materials, no fine parts, minimum noise level, uniform regrind material, easy maintenance. The new JS Series 11 is screen-less and suitable for runners recovery in-line with injection moulding machines.



Gradual cut and reduced cutting stress to the minimum thanks to the helical toothed rollers.

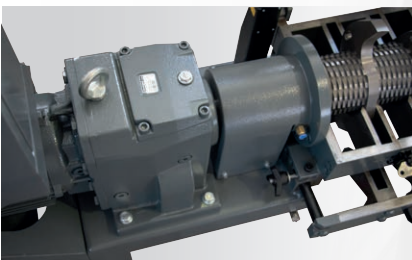

Gearmotor aligned with the rotor by interposed chain joint.

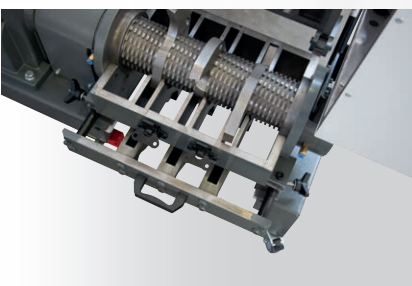

Patented cleaning system for grinding chamber.



# JS Series 11

## FEATURES JS 2811

Feeding opening (mm): 257 x 140  
Slide opening (mm): 307 x 303  
Nr. reels / rollers: 2 / 3  
Rotor speed (RPM): 25 - 30  
Reels diameter (mm): 268  
Rollers diameter (mm): 110  
Cutters dimensions (mm): 5 x 5  
Motor (kW): 0,75  
Weight (kg): 228  
Indicative throughput (kg/hr): 5 ÷ 10  
Discharge funnel capacity (lt): 7,8

## FEATURES JS 3911

Feeding opening (mm): 351 x 140  
Slide opening (mm): 307 x 397  
Nr. reels / rollers: 3 / 4  
Rotor speed (RPM): 25 - 30  
Reels diameter (mm): 268  
Rollers diameter (mm): 110  
Cutters dimensions (mm): 5 x 5  
Motor (kW): 1,5  
Weight (kg): 335  
Indicative throughput (kg/hr): 15 ÷ 20  
Discharge funnel capacity (lt): 10

## OPTIONAL

- A) Special voltages / frequencies
- B) Level control
- C) Venturi regrind material transport system

## DIMENSIONS

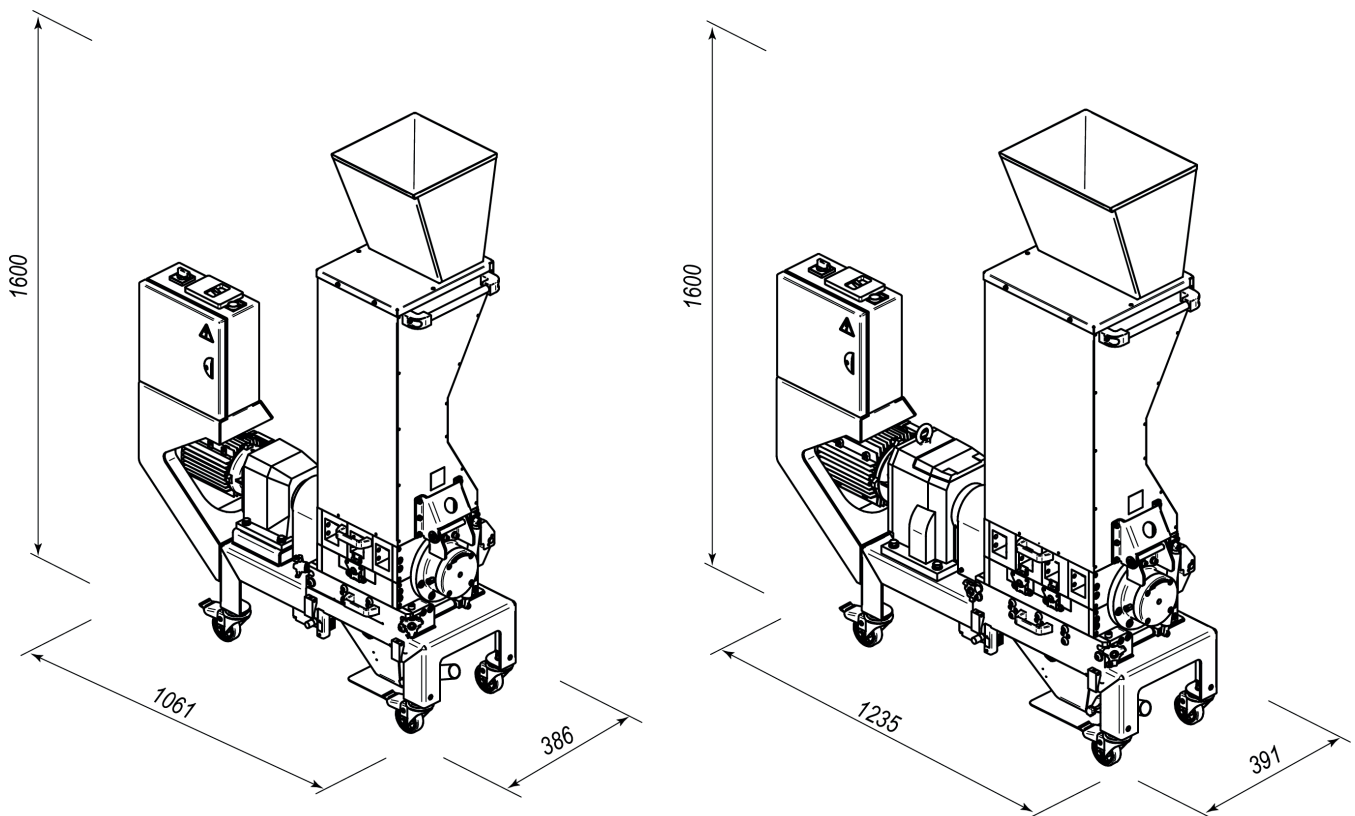

Your recycling needs. Our grinding solutions.

TRIA Italy  
[www.trioplastics.com](http://www.trioplastics.com)

TRIA America  
TRIA Brazil

TRIA China  
TRIA Germany