



Your recycling needs. Our grinding solutions.

DR SEPARATION SYSTEMS OF FINE PARTS FROM REGRIND

Regrind material depowdering and air filtering in environment from regrind material of normal consistency

Separation of regrind from its fine parts $\leq 4 \text{ mm}$

Quantity 3+5% average

Test accuracy $< 500 \mu\text{m}$

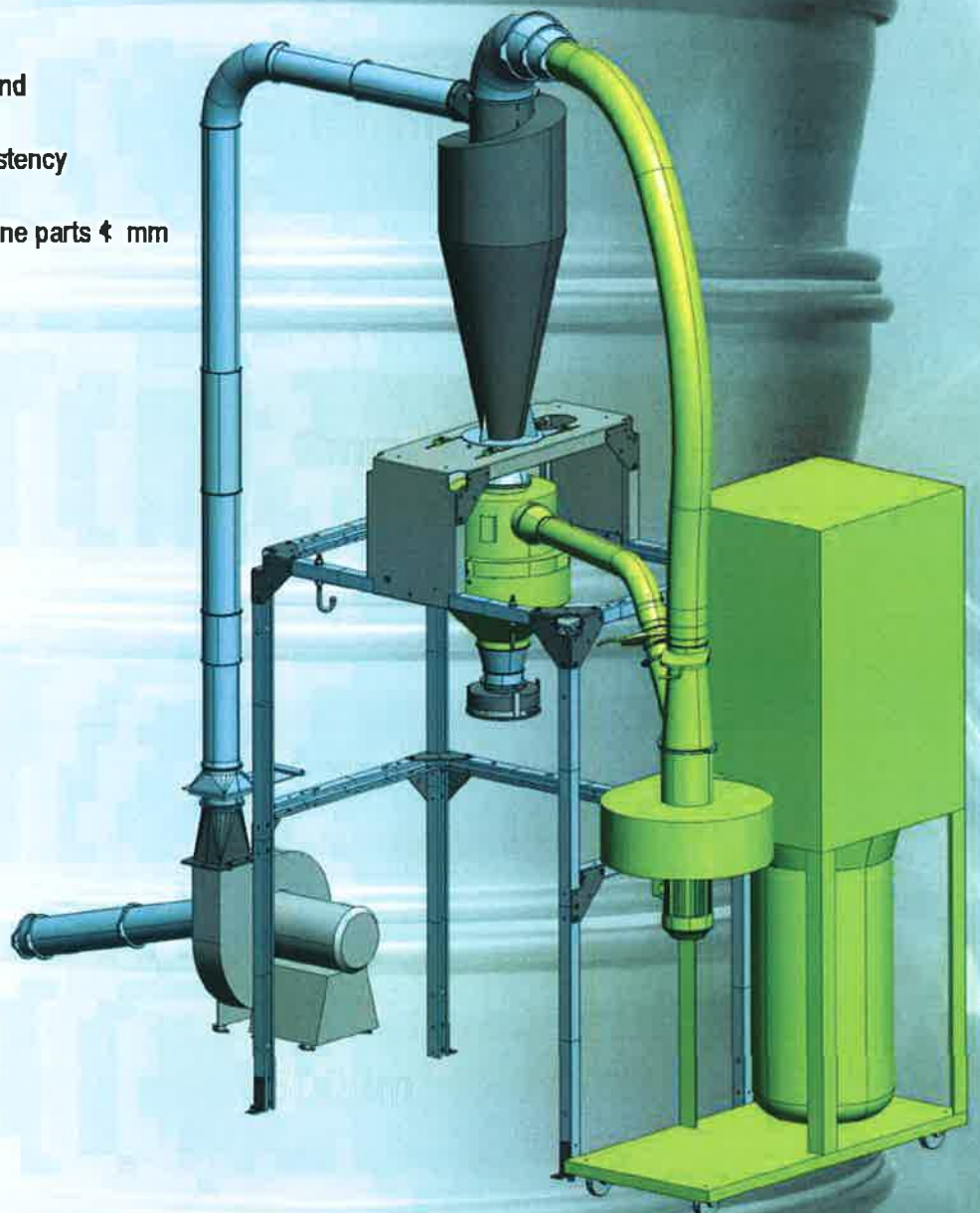

DR SEPARATION SYSTEMS OF FINE PARTS FROM REGRIND



DR body

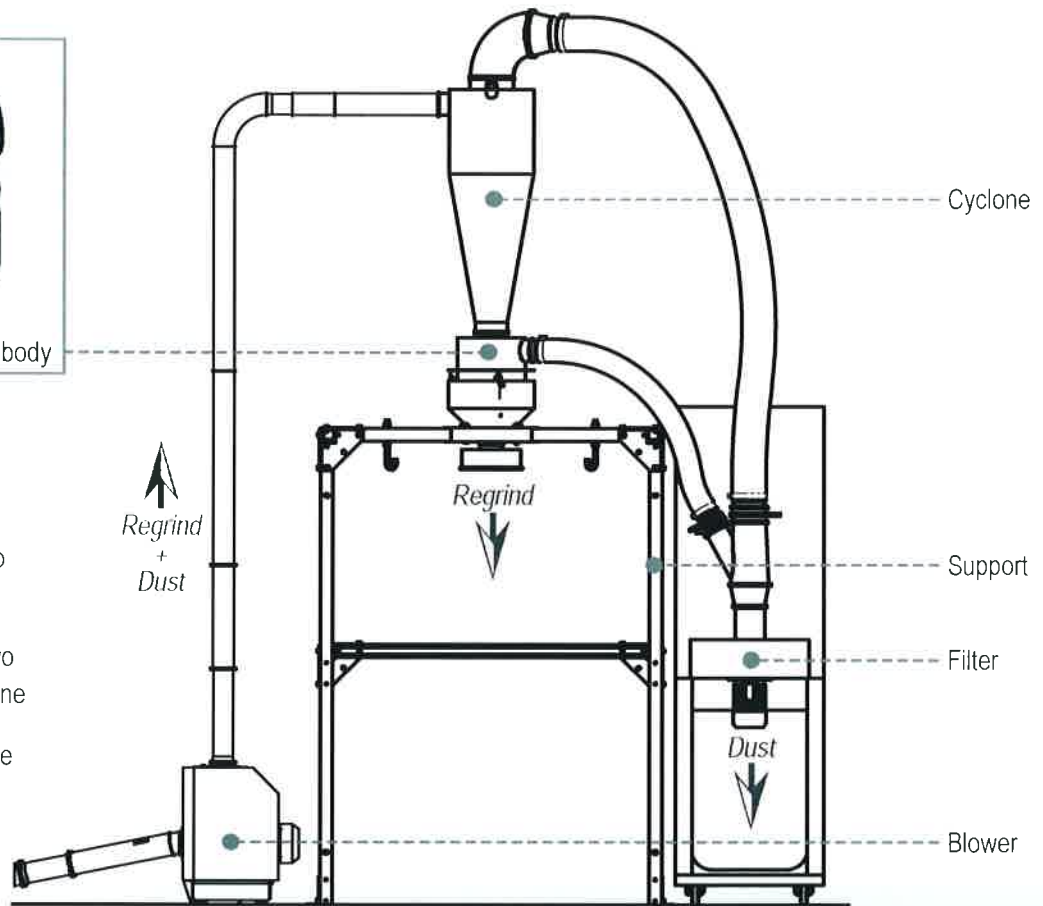

Spazio per testo descrittivo sull'impianto

O spazio per testo decriptivo sulle modalità di separazione

Oppure spazio per elencare i plus rispetto al passato

Deduster model	Blower air capacity [m ³ /h]	Blower TRIA compatible	Associated filter model	Filter surface [m ²]	Filter motor [kW]	Filter maximum capacity [m ³ /h]	Dedusting capacity [kg/h]
DR 24	500	HS 30	ALFA professional	1,6	0,75	1750	300
DR 32	800	HT 40	MINI EURO	3,0	1,50	2200	595
DR 42	1600	HT 50	EURO 1	5,0	2,20	3000	1167
DR 60	2800	HT 60	EURO 3	15,0	4,00	6500	2186
DR 80	4800	HT 70	EURO 4	20,0	5,50	10000	4400



Your recycling needs. Our grinding solutions.

TRIA S.p.A.
via E. Fermi, 8
20093 Cologno Monzese MI
ITALIA

tel +39.02.273451
fax +39.02.2542101
e-mail info@triaplastics.com
www.triaplastics.com